

2-Mbit (128 K × 16) F-RAM Memory

Features

- 2-Mbit ferroelectric random access memory (F-RAM) logically organized as 128 K × 16
 - Configurable as 256 K × 8 using \overline{UB} and \overline{LB}
 - High-endurance 100 trillion (10^{14}) read/writes
 - 151-year data retention (see the [Data Retention and Endurance](#) table)
 - NoDelay™ writes
 - Page mode operation to 30-ns cycle time
 - Advanced high-reliability ferroelectric process
- SRAM compatible
 - Industry-standard 128 K × 16 SRAM pinout
 - 60-ns access time, 110-ns cycle time
- Advanced features
 - Software-programmable block write-protect
- Superior to battery-backed SRAM modules
 - No battery concerns
 - Monolithic reliability
 - True surface mount solution, no rework steps
 - Superior for moisture, shock, and vibration
- Low power consumption
 - Active current 8 mA (typ)
 - Standby current 90 μA (typ)
 - Sleep mode current 5 μA (max)
- Low-voltage operation: $V_{DD} = 2.7\text{ V to }3.6\text{ V}$
- Industrial temperature: $-40\text{ °C to }+85\text{ °C}$

- 44-pin thin small outline package (TSOP) Type II
- Restriction of hazardous substances (RoHS) compliant

Functional Overview

The FM21L16 is a 128 K × 16 nonvolatile memory that reads and writes similar to a standard SRAM. A ferroelectric random access memory or F-RAM is nonvolatile, which means that data is retained after power is removed. It provides data retention for over 151 years while eliminating the reliability concerns, functional disadvantages, and system design complexities of battery-backed SRAM (BBSRAM). Fast write timing and high write endurance make the F-RAM superior to other types of memory.

The FM21L16 operation is similar to that of other RAM devices and therefore, it can be used as a drop-in replacement for a standard SRAM in a system. Read and write cycles may be triggered by \overline{CE} or simply by changing the address. The F-RAM memory is nonvolatile due to its unique ferroelectric memory process. These features make the FM21L16 ideal for nonvolatile memory applications requiring frequent or rapid writes.

The FM21L16 includes a low voltage monitor that blocks access to the memory array when V_{DD} drops below $V_{DD\text{ min}}$. The memory is protected against an inadvertent access and data corruption under this condition. The device also features software-controlled write protection. The memory array is divided into 8 uniform blocks, each of which can be individually write protected.

The device is available in a 400-mil, 44-pin TSOP-II surface mount package. Device specifications are guaranteed over the industrial temperature range $-40\text{ °C to }+85\text{ °C}$.

For a complete list of related documentation, click [here](#).

Logic Block Diagram

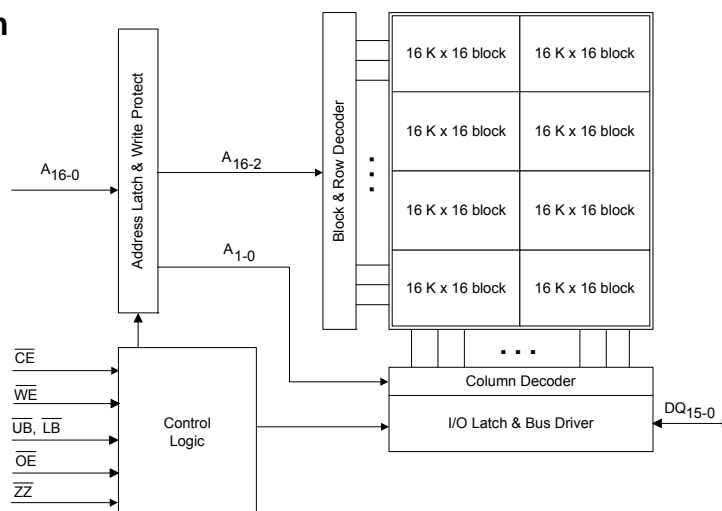

Not recommended for new designs.

Contents

Pinout	3	AC Switching Characteristics	11
Pin Definitions	3	SRAM Read Cycle	11
Device Operation	4	SRAM Write Cycle	12
Memory Operation	4	Power Cycle and Sleep Mode Timing	16
Read Operation	4	Functional Truth Table	17
Write Operation	4	Byte Select Truth Table	17
Page Mode Operation	4	Ordering Information	18
Pre-charge Operation	4	Ordering Code Definitions	18
Sleep Mode	4	Package Diagram	19
Software Write Protect	5	Acronyms	20
Software Write-Protect Timing	7	Document Conventions	20
SRAM Drop-In Replacement	8	Units of Measure	20
Maximum Ratings	9	Document History Page	21
Operating Range	9	Sales, Solutions, and Legal Information	22
DC Electrical Characteristics	9	Worldwide Sales and Design Support	22
Data Retention and Endurance	10	Products	22
Capacitance	10	PSoC® Solutions	22
Thermal Resistance	10	Cypress Developer Community	22
AC Test Conditions	10	Technical Support	22

Not recommended for new designs.

Pinout

Figure 1. 44-pin TSOP II pinout

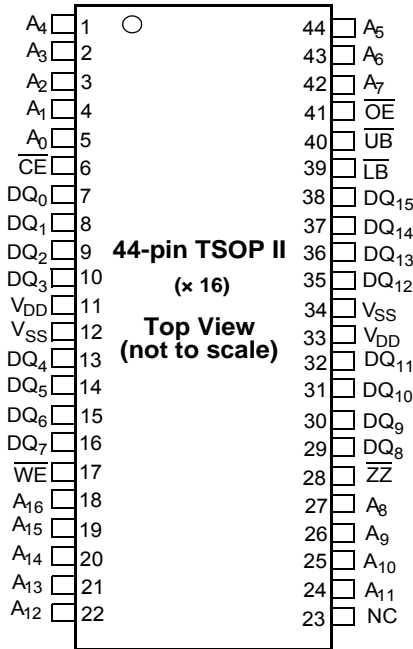

Pin Definitions

Pin Name	I/O Type	Description
A ₁₆ –A ₀	Input	Address inputs: The 17 address lines select one of 128K words in the F-RAM array. The lowest two address lines A ₁ –A ₀ may be used for page mode read and write operations.
DQ ₁₅ –DQ ₀	Input/Output	Data I/O Lines: 16-bit bidirectional data bus for accessing the F-RAM array.
\overline{WE}	Input	Write Enable: A write cycle begins when \overline{WE} is asserted. The rising edge causes the FM21L16 to write the data on the DQ bus to the F-RAM array. The falling edge of \overline{WE} latches a new column address for page mode write cycles.
\overline{CE}	Input	Chip Enable: The device is selected and a new memory access begins on the falling edge of \overline{CE} . The entire address is latched internally at this point. Subsequent changes to the A ₁ –A ₀ address inputs allow page mode operation.
\overline{OE}	Input	Output Enable: When \overline{OE} is LOW, the FM21L16 drives the data bus when the valid read data is available. Deasserting \overline{OE} HIGH tristates the DQ pins.
\overline{UB}	Input	Upper Byte Select: Enables DQ ₁₅ –DQ ₈ pins during reads and writes. These pins are HI-Z if \overline{UB} is HIGH. If the user does not perform byte writes and the device is not configured as a 256 K × 8, the \overline{UB} and \overline{LB} pins may be tied to ground.
\overline{LB}	Input	Lower Byte Select: Enables DQ ₇ –DQ ₀ pins during reads and writes. These pins are HI-Z if \overline{LB} is HIGH. If the user does not perform byte writes and the device is not configured as a 256 K × 8, the \overline{UB} and \overline{LB} pins may be tied to ground.
\overline{ZZ}	Input	Sleep: When \overline{ZZ} is LOW, the device enters a low-power sleep mode for the lowest supply current condition. \overline{ZZ} must be HIGH for a normal read/write operation. If unused, tie \overline{ZZ} pin to V _{DD} .
V _{SS}	Ground	Ground for the device. Must be connected to the ground of the system.
V _{DD}	Power supply	Power supply input to the device.
NC	No connect	No connect. This pin is not connected to the die.

Not recommended for new designs.

Device Operation

The FM21L16 is a word wide F-RAM memory logically organized as 131,072 × 16 and accessed using an industry-standard parallel interface. All data written to the part is immediately nonvolatile with no delay. The device offers page mode operation, which provides high-speed access to addresses within a page (row). Access to a different page requires that either \overline{CE} transitions LOW or the upper address ($A_{16}-A_2$) changes. See the [Functional Truth Table on page 17](#) for a complete description of read and write modes.

Memory Operation

Users access 131,072 memory locations, each with 16 data bits through a parallel interface. The F-RAM array is organized as eight blocks, each having 4096 rows. Each row has four column locations, which allow fast access in page mode operation. When an initial address is latched by the falling edge of \overline{CE} , subsequent column locations may be accessed without the need to toggle \overline{CE} . When \overline{CE} is deasserted HIGH, a pre-charge operation begins. Writes occur immediately at the end of the access with no delay. The \overline{WE} pin must be toggled for each write operation. The write data is stored in the nonvolatile memory array immediately, which is a feature unique to F-RAM called NoDelay writes.

Read Operation

A read operation begins on the falling edge of \overline{CE} . The falling edge of \overline{CE} causes the address to be latched and starts a memory read cycle if \overline{WE} is HIGH. Data becomes available on the bus after the access time is met. When the address is latched and the access completed, a new access to a random location (different row) may begin while \overline{CE} is still LOW. The minimum cycle time for random addresses is t_{RC} . Note that unlike SRAMs, the FM21L16's \overline{CE} -initiated access time is faster than the address access time.

The FM21L16 will drive the data bus when \overline{OE} and at least one of the byte enables (\overline{UB} , \overline{LB}) is asserted LOW. The upper data byte is driven when \overline{UB} is LOW, and the lower data byte is driven when \overline{LB} is LOW. If \overline{OE} is asserted after the memory access time is met, the data bus will be driven with valid data. If \overline{OE} is asserted before completing the memory access, the data bus will not be driven until valid data is available. This feature minimizes supply current in the system by eliminating transients caused by invalid data being driven to the bus. When \overline{OE} is deasserted HIGH, the data bus will remain in a HI-Z state.

Write Operation

In the FM21L16, writes occur in the same interval as reads. The FM21L16 supports both \overline{CE} and \overline{WE} controlled write cycles. In both cases, the address $A_{16}-A_2$ is latched on the falling edge of \overline{CE} .

In a \overline{CE} -controlled write, the \overline{WE} signal is asserted before beginning the memory cycle. That is, \overline{WE} is LOW when \overline{CE} falls. In this case, the device begins the memory cycle as a write. The FM21L16 will not drive the data bus regardless of the state of \overline{OE} as long as \overline{WE} is LOW. Input data must be valid when \overline{CE} is

deasserted HIGH. In a \overline{WE} -controlled write, the memory cycle begins on the falling edge of \overline{CE} . The \overline{WE} signal falls some time later. Therefore, the memory cycle begins as a read. The data bus will be driven if \overline{OE} is LOW; however, it will be HI-Z when \overline{WE} is asserted LOW. The \overline{CE} - and \overline{WE} -controlled write timing cases are shown in the [page 14](#).

Write access to the array begins on the falling edge of \overline{WE} after the memory cycle is initiated. The write access terminates on the rising edge of \overline{WE} or \overline{CE} , whichever comes first. A valid write operation requires the user to meet the access time specification before deasserting \overline{WE} or \overline{CE} . The data setup time indicates the interval during which data cannot change before the end of the write access (rising edge of \overline{WE} or \overline{CE}).

Unlike other nonvolatile memory technologies, there is no write delay with F-RAM. Because the read and write access times of the underlying memory are the same, the user experiences no delay through the bus. The entire memory operation occurs in a single bus cycle. Data polling, a technique used with EEPROMs to determine if a write is complete, is unnecessary.

Page Mode Operation

The F-RAM array is organized as eight blocks, each having 4096 rows. Each row has four column-address locations. Address inputs A_1-A_0 define the column address to be accessed. An access can start on any column address, and other column locations may be accessed without the need to toggle the \overline{CE} pin. For fast access reads, after the first data byte is driven to the bus, the column address inputs A_1-A_0 may be changed to a new value. A new data byte is then driven to the DQ pins no later than t_{AAP} , which is less than half the initial read access time. For fast access writes, the first write pulse defines the first write access. While \overline{CE} is LOW, a subsequent write pulse along with a new column address provides a page mode write access.

Pre-charge Operation

The pre-charge operation is an internal condition in which the memory state is prepared for a new access. Pre-charge is user-initiated by driving the \overline{CE} signal HIGH. It must remain HIGH for at least the minimum pre-charge time, t_{PC} .

Pre-charge is also activated by changing the upper addresses, $A_{16}-A_2$. The current row is first closed before accessing the new row. The device automatically detects an upper order address change, which starts a pre-charge operation. The new address is latched and the new read data is valid within the t_{AA} address access time; see [Figure 9 on page 13](#). A similar sequence occurs for write cycles; see [Figure 14 on page 14](#). The rate at which random addresses can be issued is t_{RC} and t_{WC} , respectively.

Sleep Mode

The device incorporates a sleep mode of operation, which allows the user to achieve the lowest power supply current condition. It enters a low-power sleep mode by asserting the \overline{ZZ} pin LOW. Read and write operations must complete before the \overline{ZZ} pin going LOW. When \overline{ZZ} is LOW, all pins are ignored except the \overline{ZZ} pin. When \overline{ZZ} is deasserted HIGH, there is some time delay (t_{ZZEX}) before the user can access the device.

If sleep mode is not used, the \overline{ZZ} pin should be tied to V_{DD} .

Figure 2. Sleep/Standby State Diagram

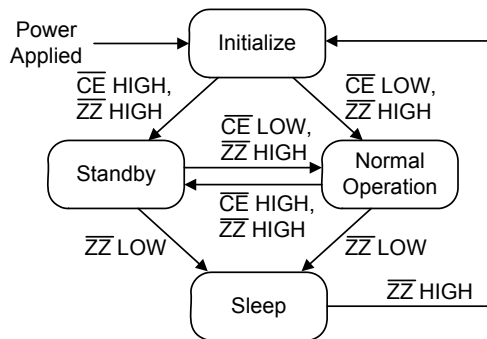

Software Write Protect

The 128 K × 16 address space is divided into eight sectors (blocks) of 16 K × 16 each. Each sector can be individually software write-protected and the settings are nonvolatile. A unique address and command sequence invokes the write-protect mode.

To modify write protection, the system host must issue six read commands, three write commands, and a final read command. The specific sequence of read addresses must be provided to access the write-protect mode. Following the read address sequence, the host must write a data byte that specifies the desired protection state of each sector. For confirmation, the system must then write the complement of the protection byte immediately after the protection byte. Any error that occurs including read addresses in the wrong order, issuing a seventh read address, or failing to complement the protection value will leave the write protection unchanged.

The write-protect state machine monitors all addresses, taking no action until this particular read/write sequence occurs. During the address sequence, each read will occur as a valid operation and data from the corresponding addresses will be driven to the data bus. Any address that occurs out of sequence will cause the software protection state machine to start over. After the address sequence is completed, the next operation must be a write cycle. The lower data byte contains the write-protect settings. This value will not be written to the memory array, so the address is a don't-care. Rather it will be held pending the next cycle, which must be a write of the data complement to the protection settings. If the complement is correct, the write-protect settings will be adjusted. Otherwise, the process is aborted and the address sequence starts over. The data value written after the correct six addresses will not be entered into the memory.

The protection data byte consists of eight bits, each associated with the write-protect state of a sector. The data byte must be driven to the lower eight bits of the data bus, DQ₇ - DQ₀. Setting a bit to '1' write-protects the corresponding sector; a '0' enables writes for that sector. The following table shows the write-protect sectors with the corresponding bit that controls the write-protect setting.

Table 1. Write Protect Sectors - 16 K × 16 Blocks

Sectors	Blocks
Sector 7	1FFFFh–1C000h
Sector 6	1BFFFh–18000h
Sector 5	17FFFh–14000h
Sector 4	13FFFh–10000h
Sector 3	0FFFFh–0C000h
Sector 2	0BFFFh–08000h
Sector 1	07FFFh–04000h
Sector 0	03FFFh–00000h

The write-protect address sequence follows:

1. Read address 12555h
2. Read address 1DAAAh
3. Read address 01333h
4. Read address 0ECCCh
5. Read address 00FFh
6. Read address 1FF00h
7. Write address 1DAAAh
8. Write address 0ECCCh
9. Write address 0FF00h
10. Read address 00000h

Note If \overline{CE} is LOW entering the sequence, then an address of 00000h must precede 12555h.

The address sequence provides a secure way of modifying the protection. The write-protect sequence has a one in 3×10^{32} chance of randomly accessing exactly the first six addresses. The odds are further reduced by requiring three more write cycles, one that requires an exact inversion of the data byte. [Figure 3 on page 6](#) shows a flow chart of the entire write-protect operation. The write-protect settings are nonvolatile. The factory default: all blocks are unprotected.

For example, the following sequence write-protects addresses from 0C000h to 13FFFh (sectors 3 and 4):

	Address	Data
Read	12555h	–
Read	1DAAAh	–
Read	01333h	–
Read	0ECCCh	–
Read	00FFh	–
Read	1FF00h	–
Write	1DAAAh	18h; bits 3 and 4 = 1
Write	0ECCCh	E7h; complement of 18h
Write	0FF00h	Don't care
Read	00000h	

Not recommended for new designs.

Figure 3. Write-Protect State Machine

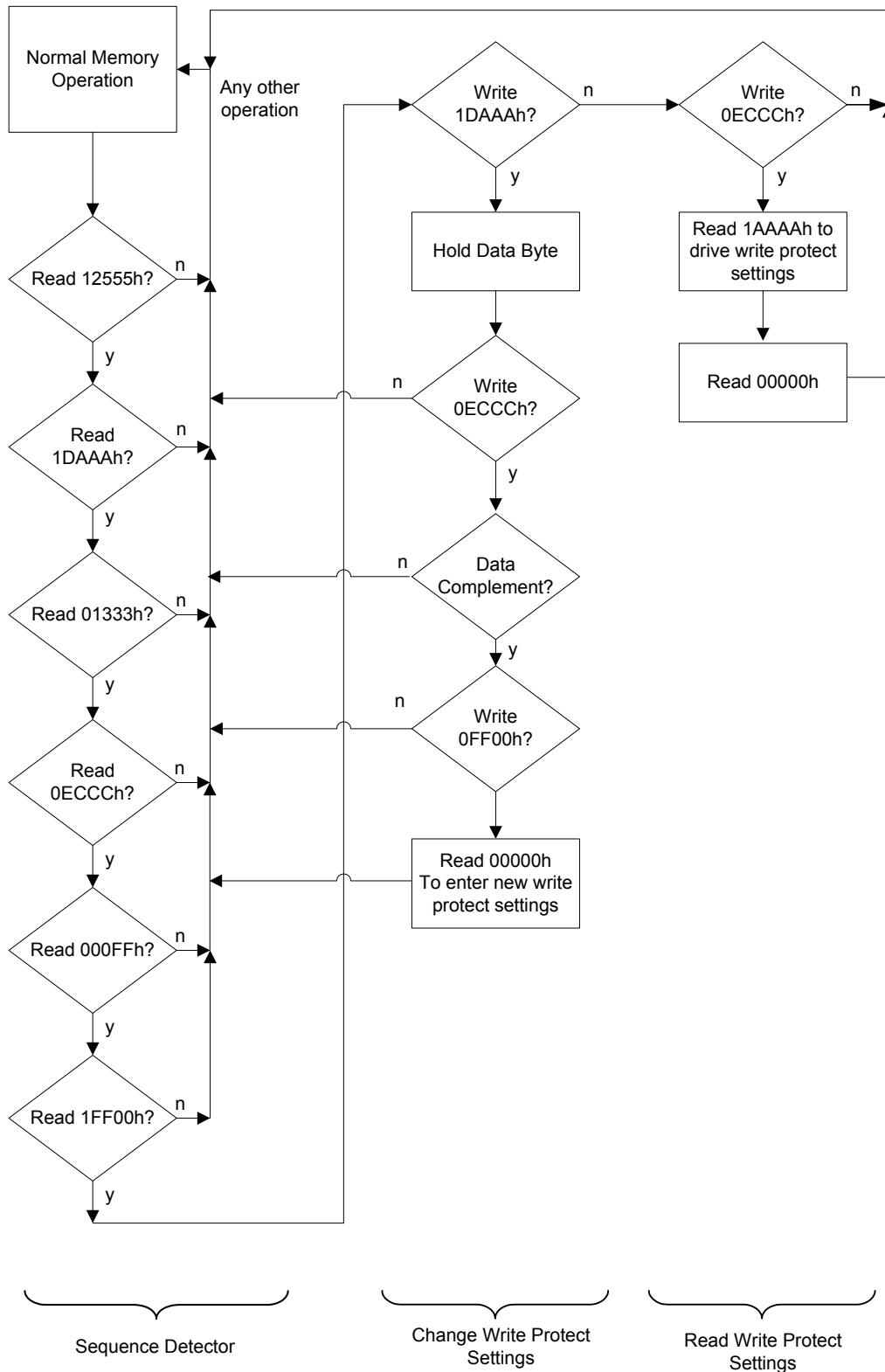

Not recommended for new designs.

Software Write-Protect Timing

Figure 4. Sequence to Set Write-Protect Blocks [1]

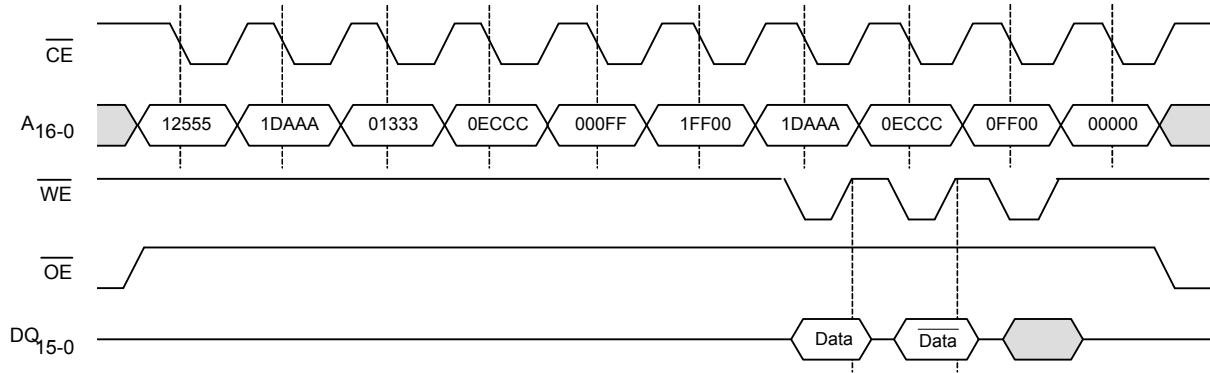
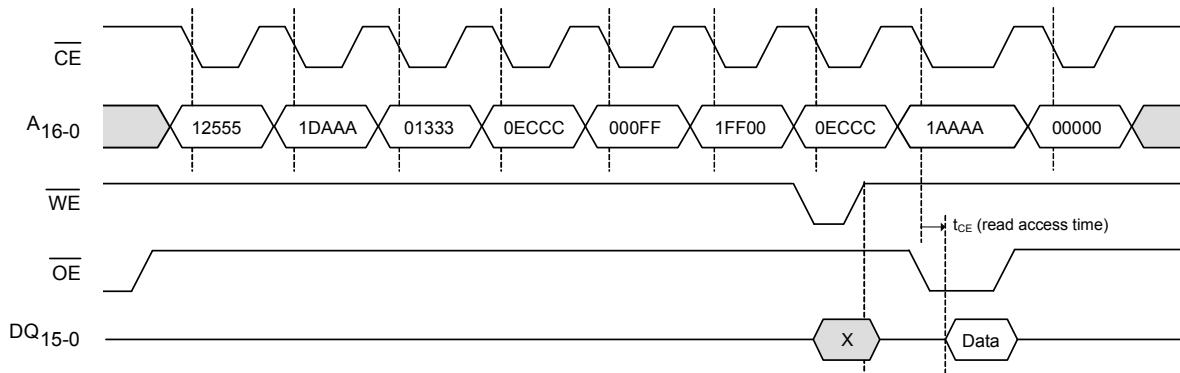

Figure 5. Sequence to Read Write-Protect Settings [1]



Note

1. This sequence requires $t_{AS} \geq 10$ ns and address must be stable while \overline{CE} is LOW.

SRAM Drop-In Replacement

The FM21L16 is designed to be a drop-in replacement for standard asynchronous SRAMs. The device does not require \overline{CE} to toggle for each new address. \overline{CE} may remain LOW for as long as 10 μ s. While \overline{CE} is LOW, the device automatically detects address changes and a new access begins. It also allows page mode operation at speeds up to 33 MHz.

Figure 6 shows a pull-up resistor on \overline{CE} , which will keep the pin HIGH during power cycles, assuming the MCU / MPU pin tristates during the reset condition. The pull-up resistor value should be chosen to ensure the CE pin tracks V_{DD} to a high enough value, so that the current drawn when \overline{CE} is LOW is not an issue. A 10-k Ω resistor draws 330 μ A when \overline{CE} is LOW and $V_{DD} = 3.3$ V

Figure 6. Use of Pull-up Resistor on \overline{CE}

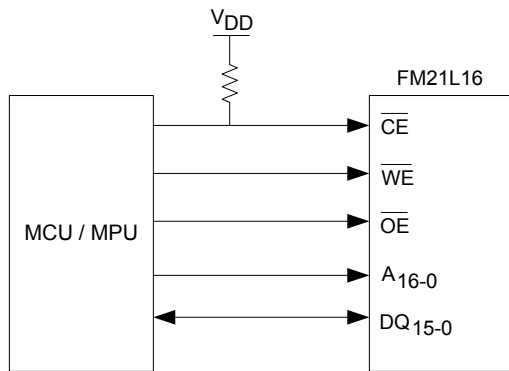

Note that if \overline{CE} is tied to ground, the user must be sure \overline{WE} is not LOW at power-up or power-down events. If CE and WE are both LOW during power cycles, data will be corrupted. Figure 7 shows a pull-up resistor on \overline{WE} , which will keep the pin HIGH during power cycles, assuming the MCU / MPU pin tristates during the reset condition. The pull-up resistor value should be chosen to ensure the WE pin tracks V_{DD} to a high enough value, so that

the current drawn when \overline{WE} is LOW is not an issue. A 10-k Ω resistor draws 330 μ A when \overline{WE} is LOW and $V_{DD} = 3.3$ V.

Figure 7. Use of Pull-up Resistor on \overline{WE}

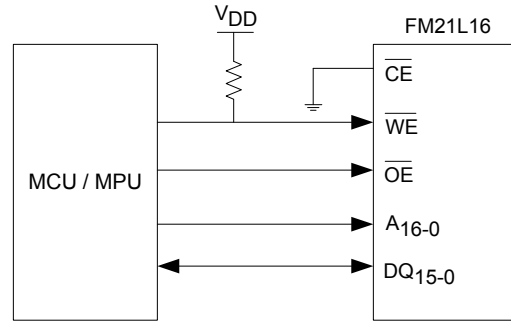

Note If \overline{CE} is tied to ground, the user gives up the ability to perform the software write-protect sequence.

For applications that require the lowest power consumption, the \overline{CE} signal should be active (LOW) only during memory accesses. The FM21L16 draws supply current while \overline{CE} is LOW, even if addresses and control signals are static. While \overline{CE} is HIGH, the device draws no more than the maximum standby current, I_{SB} . \overline{CE} toggling LOW on every address access is perfectly acceptable in FM21L16.

The \overline{UB} and \overline{LB} byte select pins are active for both read and write cycles. They may be used to allow the device to be wired as a 256 K \times 8 memory. The upper and lower data bytes can be tied together and controlled with the byte selects. Individual byte enables or the next higher address line A_{17} may be available from the system processor.

Figure 8. FM21L16 Wired as 256 K \times 8

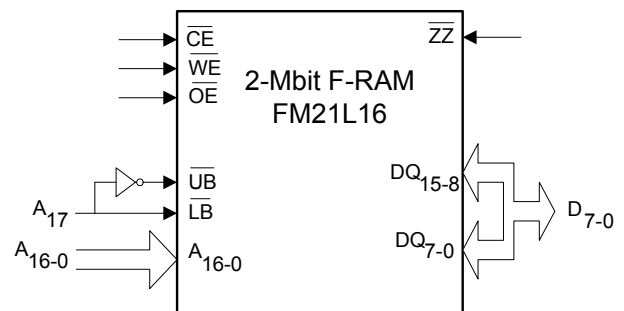

Not recommended for new designs.

Maximum Ratings

Exceeding maximum ratings may shorten the useful life of the device. These user guidelines are not tested.

Storage temperature	-55 °C to +125 °C
Maximum accumulated storage time	
At 125 °C ambient temperature	1000 h
At 85 °C ambient temperature	10 Years
Ambient temperature	
with power applied	-55 °C to +125 °C
Supply voltage on V_{DD} relative to V_{SS}	-1.0 V to + 4.5 V
Voltage applied to outputs	
in High Z state	-0.5 V to $V_{DD} + 0.5$ V
Input voltage	-1.0 V to + 4.5 V and $V_{IN} < V_{DD} + 1.0$ V
Transient voltage (< 20 ns) on	
any pin to ground potential	-2.0 V to $V_{CC} + 2.0$ V

Package power dissipation capability ($T_A = 25$ °C)	1.0 W
Surface mount Pb soldering temperature (3 seconds)	+260 °C
DC output current (1 output at a time, 1s duration)	15 mA
Static discharge voltage	
Human Body Model (JEDEC Std JESD22-A114-F)	2.5 kV
Charged Device Model (JEDEC Std JESD22-C101-D)	800 V
Machine Model (JEDEC Std JESD22-A115-A)	200 V
Latch-up current	> 140 mA

Operating Range

Range	Ambient Temperature (T_A)	V_{DD}
Industrial	-40 °C to +85 °C	2.7 V to 3.6 V

DC Electrical Characteristics

Over the [Operating Range](#)

Parameter	Description	Test Conditions	Min	Typ ^[2]	Max	Unit	
V_{DD}	Power supply voltage		2.7	3.3	3.6	V	
I_{DD}	V_{DD} supply current	$V_{DD} = 3.6$ V, \overline{CE} cycling at min. cycle time. All inputs toggling at CMOS levels (0.2 V or $V_{DD} - 0.2$ V), all DQ pins unloaded.	-	8	12	mA	
I_{SB}	Standby current	$V_{DD} = 3.6$ V, \overline{CE} at V_{DD} . All other pins are static and at CMOS levels (0.2 V or $V_{DD} - 0.2$ V), \overline{ZZ} is HIGH	$T_A = 25$ °C	-	90	150	μ A
			$T_A = 85$ °C	-	-	270	μ A
I_{ZZ}	Sleep mode current	$V_{DD} = 3.6$ V, \overline{ZZ} is LOW, all other inputs at CMOS levels (0.2 V or $V_{DD} - 0.2$ V).	$T_A = 25$ °C	-	-	5	μ A
			$T_A = 85$ °C	-	-	8	μ A
I_{LI}	Input leakage current	V_{IN} between V_{DD} and V_{SS}	-	-	± 1	μ A	
I_{LO}	Output leakage current	V_{OUT} between V_{DD} and V_{SS}	-	-	± 1	μ A	
V_{IH}	Input HIGH voltage		2.2	-	$V_{DD} + 0.3$	V	
V_{IL}	Input LOW voltage		-0.3	-	0.6	V	
V_{OH1}	Output HIGH voltage	$I_{OH} = -1.0$ mA	2.4	-	-	V	
V_{OH2}	Output HIGH voltage	$I_{OH} = -100$ μ A	$V_{DD} - 0.2$	-	-	V	
V_{OL1}	Output LOW voltage	$I_{OL} = 2.1$ mA	-	-	0.4	V	
V_{OL2}	Output LOW voltage	$I_{OL} = 100$ μ A	-	-	0.2	V	

Note

2. Typical values are at 25 °C, $V_{DD} = V_{DD}$ (typ). Not 100% tested.

Data Retention and Endurance

Parameter	Description	Test condition	Min	Max	Unit
T _{DR}	Data retention	T _A = 85 °C	10	–	Years
		T _A = 75 °C	38	–	
		T _A = 65 °C	151	–	
NV _C	Endurance	Over operating temperature	10 ¹⁴	–	Cycles

Capacitance

Parameter	Description	Test Conditions	Max	Unit
C _{I/O}	Input/Output capacitance (DQ)	T _A = 25 °C, f = 1 MHz, V _{DD} = V _{DD} (Typ)	8	pF
C _{IN}	Input capacitance		6	pF
C _{ZZ}	Input capacitance of \overline{ZZ} pin		8	pF

Thermal Resistance

Parameter	Description	Test Conditions	44-pin TSOP II	Unit
Θ _{JA}	Thermal resistance (junction to ambient)	Test conditions follow standard test methods and procedures for measuring thermal impedance, in accordance with EIA/JESD51.	102	°C/W
Θ _{JC}	Thermal resistance (junction to case)		22	°C/W

AC Test Conditions

Input pulse levels 0 V to 3 V
 Input rise and fall times (10%–90%) ≤ 3 ns
 Input and output timing reference levels 1.5 V
 Output load capacitance 30 pF

Not recommended for new designs.

AC Switching Characteristics

 Over the [Operating Range](#)

Parameters ^[3]		Description	Min	Max	Unit
Cypress Parameter	Alt Parameter				
SRAM Read Cycle					
t _{CE}	t _{ACE}	Chip enable access time	–	60	ns
t _{RC}	–	Read cycle time	110	–	ns
t _{AA}	–	Address access time	–	110	ns
t _{OH}	t _{OHA}	Output hold time	20	–	ns
t _{AAP}	–	Page mode address access time	–	25	ns
t _{OHP}	–	Page mode output hold time	5	–	ns
t _{CA}	–	Chip enable active time	60	10,000	ns
t _{PC}	–	Pre-charge time	50	–	ns
t _{BA}	t _{BW}	\overline{UB} , \overline{LB} access time	–	20	ns
t _{AS}	t _{SA}	Address setup time (to \overline{CE} LOW)	0	–	ns
t _{AH}	t _{HA}	Address hold time (\overline{CE} Controlled)	60	–	ns
t _{OE}	t _{DOE}	Output enable access time	–	15	ns
t _{HZ} ^[4, 5]	t _{HZCE}	Chip Enable to output HI-Z	–	10	ns
t _{OHZ} ^[4, 5]	t _{HZOE}	Output enable HIGH to output HI-Z	–	10	ns
t _{BHZ} ^[4, 5]	t _{HZBE}	\overline{UB} , \overline{LB} HIGHHIGH to output HI-Z	–	10	ns

Not recommended for new designs.

Notes

- Test conditions assume a signal transition time of 3 ns or less, timing reference levels of $0.5 \times V_{DD}$, input pulse levels of 0 to 3 V, output loading of the specified I_{OL}/I_{OH} and load capacitance shown in [AC Test Conditions on page 10](#).
- t_{HZ}, t_{OHZ} and t_{BHZ} are specified with a load capacitance of 5 pF. Transition is measured when the outputs enter a high impedance state.
- This parameter is characterized but not 100% tested.

AC Switching Characteristics (continued)

 Over the [Operating Range](#)

Parameters ^[3]		Description	Min	Max	Unit
Cypress Parameter	Alt Parameter				
SRAM Write Cycle					
t_{WC}	t_{WC}	Write cycle time	110	–	ns
t_{CA}	–	Chip enable active time	60	10,000	ns
t_{CW}	t_{SCE}	Chip enable to write enable HIGH	60	–	ns
t_{PC}	–	Pre-charge time	50	–	ns
t_{PWC}	–	Page mode write enable cycle time	25	–	ns
t_{WP}	t_{PWE}	Write enable pulse width	16	–	ns
t_{AS}	t_{SA}	Address setup time (to \overline{CE} LOW)	0	–	ns
t_{ASP}	–	Page mode address setup time (to \overline{WE} LOW)	8	–	ns
t_{AHP}	–	Page mode address hold time (to \overline{WE} LOW)	15	–	ns
t_{WLC}	t_{PWE}	Write enable LOW to chip disabled	25	–	ns
t_{BLC}	t_{BW}	\overline{UB} , \overline{LB} LOW to chip disabled	25	–	ns
t_{WLA}	–	Write enable LOW to A_{16-2} change	25	–	ns
t_{AWH}	–	A_{16-2} change to write enable HIGH	110	–	ns
t_{DS}	t_{SD}	Data input setup time	14	–	ns
t_{DH}	t_{HD}	Data input hold time	0	–	ns
$t_{WZ}^{[6, 7]}$	t_{HZWE}	Write enable LOW to output HI-Z	–	10	ns
$t_{WX}^{[7]}$	–	Write enable HIGH to output driven	10	–	ns
$t_{WS}^{[8]}$	–	Write enable to \overline{CE} LOW setup time	0	–	ns
$t_{WH}^{[8]}$	–	Write enable to \overline{CE} HIGH hold time	0	–	ns

Not recommended for new designs.

Notes

6. t_{WZ} is specified with a load capacitance of 5 pF. Transition is measured when the outputs enter a high impedance state.
7. This parameter is characterized but not 100% tested.
8. The relationship between \overline{CE} and \overline{WE} determines if a \overline{CE} - or \overline{WE} -controlled write occurs. The parameters t_{WS} and t_{WH} are not tested.

Figure 9. Read Cycle Timing 1 (\overline{CE} LOW, \overline{OE} LOW)

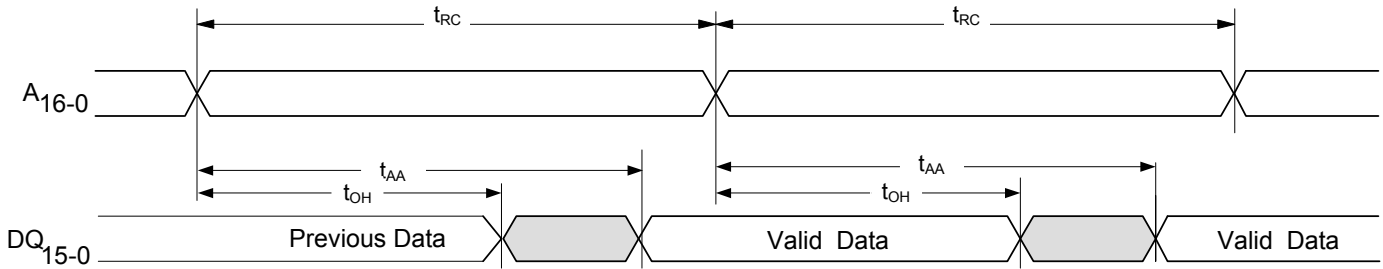

Figure 10. Read Cycle Timing 2 (\overline{CE} Controlled)

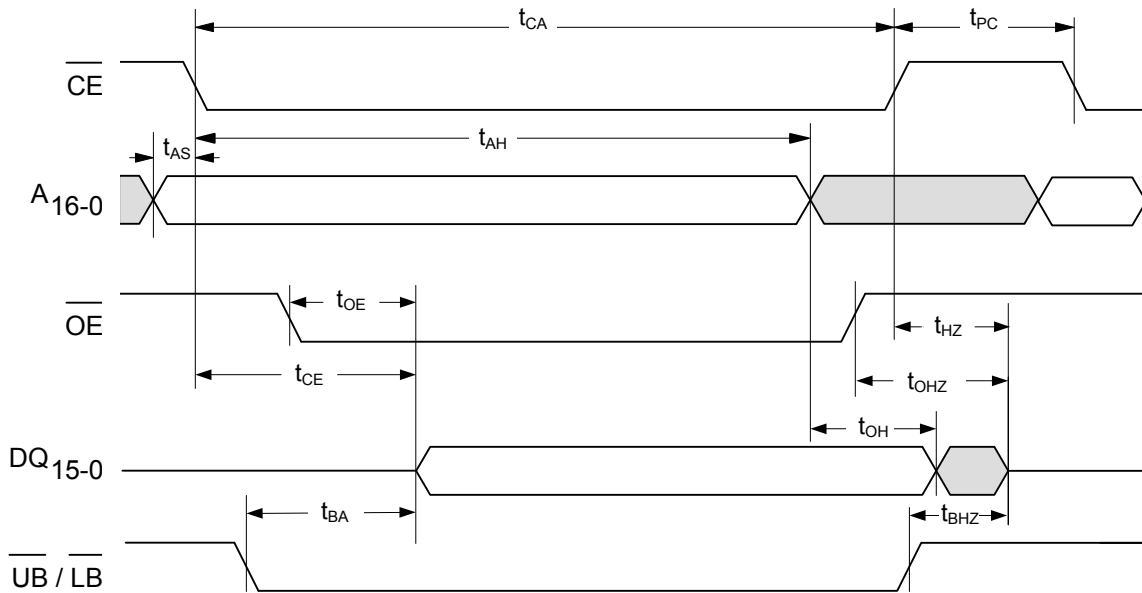
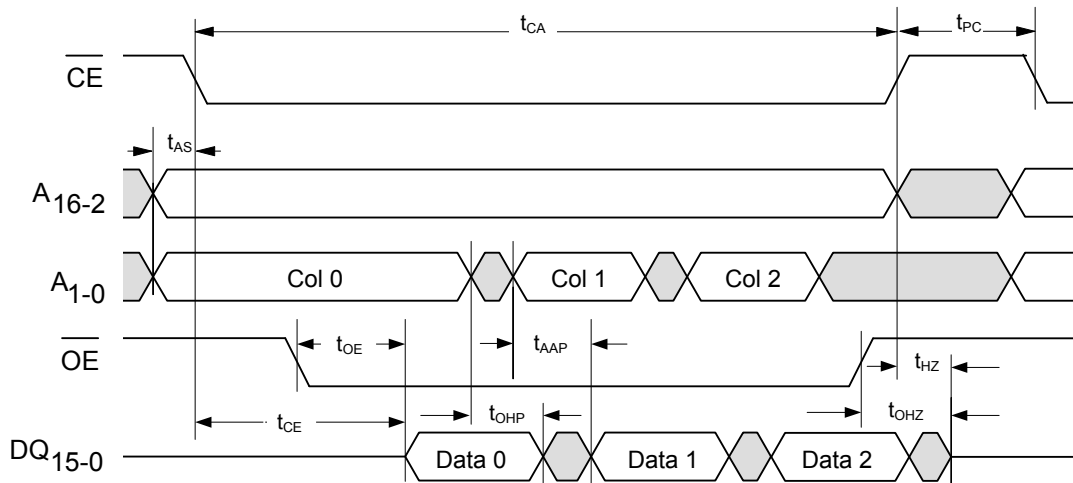

Figure 11. Page Mode Read Cycle Timing^[9]



Note

9. Although sequential column addressing is shown, it is not required

Not recommended for new designs.

Figure 12. Write Cycle Timing 1 (\overline{WE} Controlled) [10]

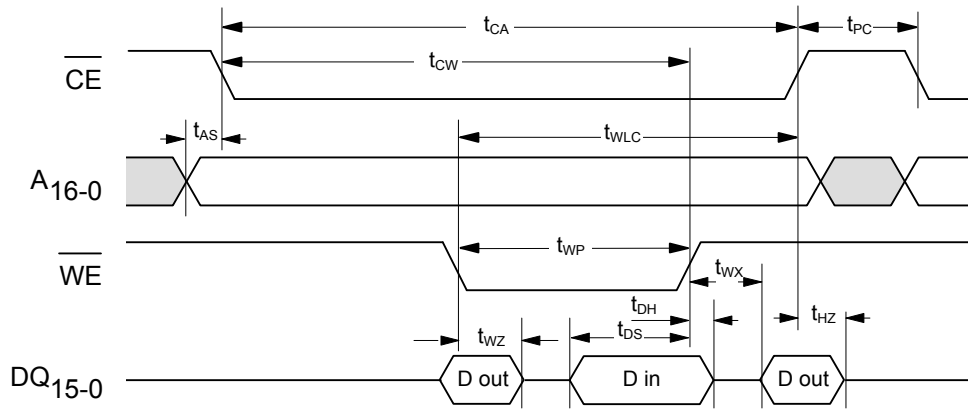

Figure 13. Write Cycle Timing 2 (\overline{CE} Controlled)

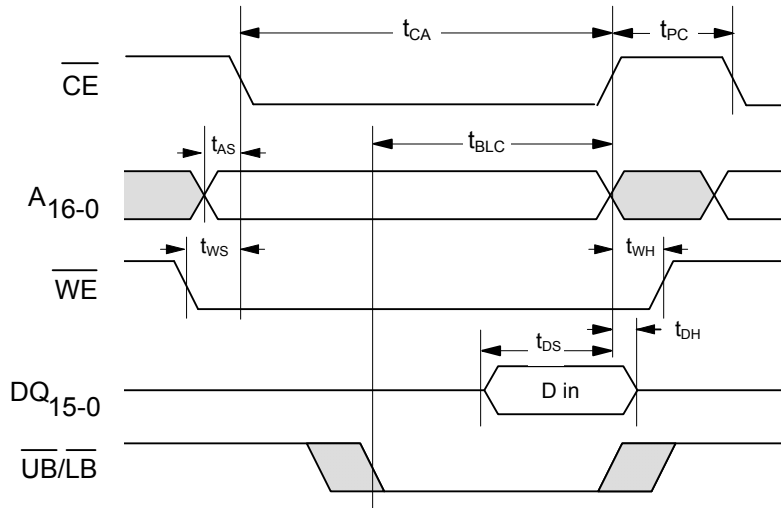
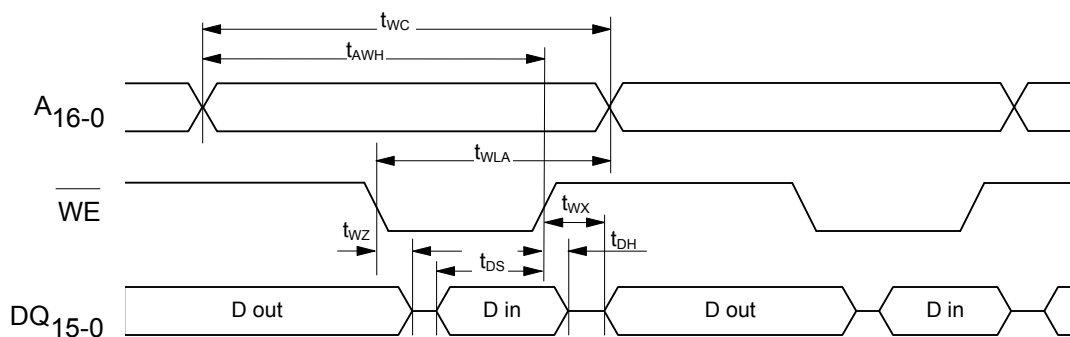

Figure 14. Write Cycle Timing 3 (\overline{CE} LOW) [10]



Note
10. \overline{OE} (not shown) is LOW only to show the effect of \overline{WE} on DQ pins.

Not recommended for new designs.

Figure 15. Page Mode Write Cycle Timing

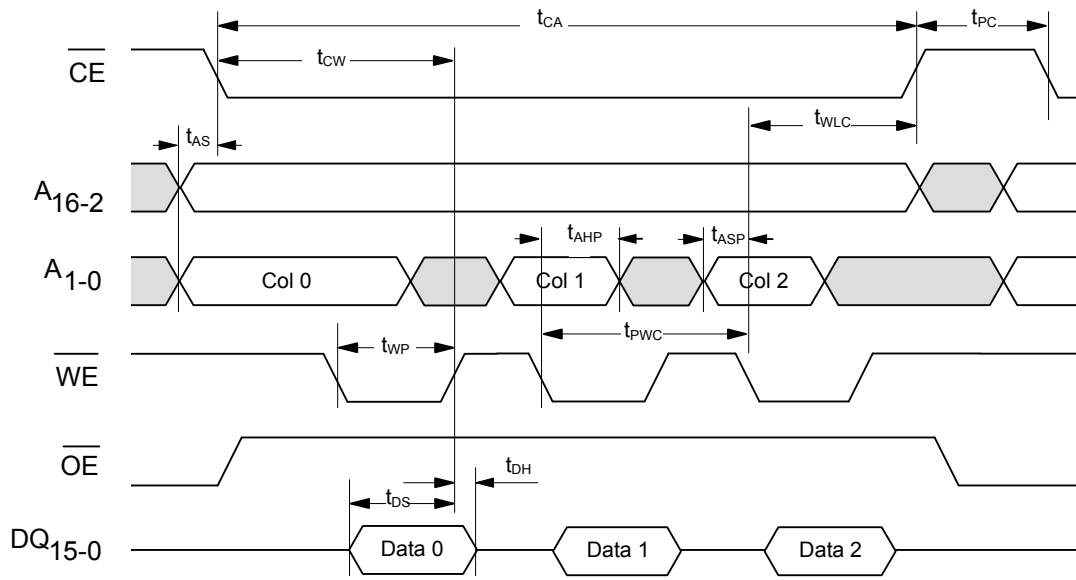

Not recommended for new designs.

Note
11. UB and LB to show byte enable and byte masking cases.

Power Cycle and Sleep Mode Timing

Over the [Operating Range](#)

Parameter	Description	Min	Max	Unit
t_{PU}	Power-up (after V_{DD} min. is reached) to first access time	450	–	μs
t_{PD}	Last write (\overline{WE} HIGH) to power down time	0	–	μs
$t_{VR}^{[12, 13]}$	V_{DD} power-up ramp rate	50	–	$\mu s/V$
$t_{VF}^{[12, 13]}$	V_{DD} power-down ramp rate	100	–	$\mu s/V$
t_{ZZH}	\overline{ZZ} active to DQ HI-Z time	–	20	ns
t_{WEZZ}	Last write to sleep mode entry time	0	–	μs
t_{ZZL}	\overline{ZZ} active LOW time	1	–	μs
t_{ZZEN}	Sleep mode entry time (\overline{ZZ} LOW to \overline{CE} don't care)	–	0	μs
t_{ZZEX}	Sleep mode exit time (\overline{ZZ} HIGH to 1 st access after wakeup)	–	450	μs

Figure 16. Power Cycle and Sleep Mode Timing

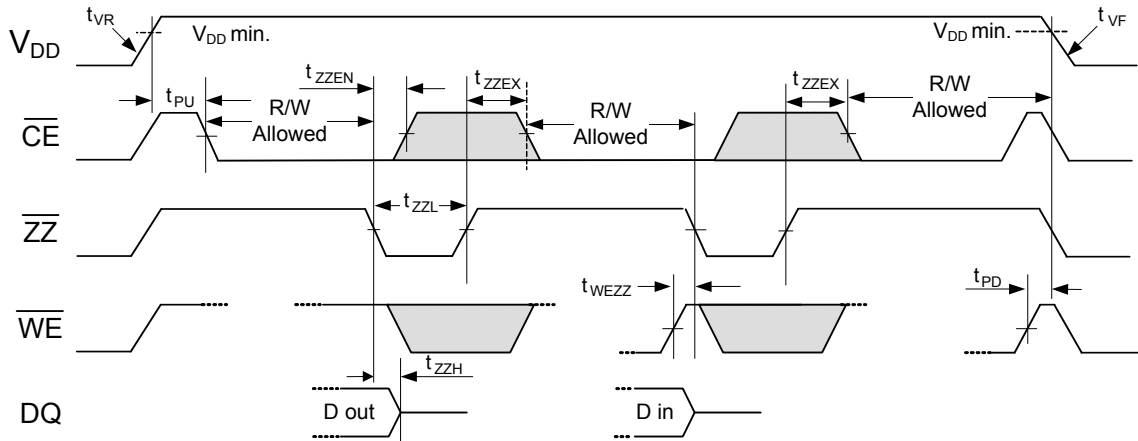

Note

- 12. Slope measured at any point on the V_{DD} waveform.
- 13. Cypress cannot test or characterize all V_{DD} power ramp profiles. The behavior of the internal circuits is difficult to predict when V_{DD} is below the level of a transistor threshold voltage. Cypress strongly recommends that V_{DD} power up faster than 100 ns through the range of 0.4 V to 1.0 V.

Functional Truth Table

\overline{CE}	\overline{WE}	A ₁₆₋₂	A ₁₋₀	\overline{ZZ}	Operation ^[14, 15]
X	X	X	X	L	Sleep Mode
H	X	X	X	H	Standby/Idle
↓ L	H H	V V	V V	H H	Read
L	H	No Change	Change	H	Page Mode Read
L	H	Change	V	H	Random Read
↓ L	L L	V V	V V	H H	\overline{CE} -Controlled Write ^[15]
L	↓	V	V	H	\overline{WE} -Controlled Write ^[15, 16]
L	↓	No Change	V	H	Page Mode Write ^[17]
↑ L	X X	X X	X X	H H	Starts pre-charge

Byte Select Truth Table

\overline{WE}	\overline{OE}	\overline{LB}	\overline{UB}	Operation ^[18]
H	H	X	X	Read; Outputs disabled
	X	H	H	
H	L	H	L	Read upper byte; HI-Z lower byte
		L	H	Read lower byte; HI-Z upper byte
		L	L	Read both bytes
L	X	H	L	Write upper byte; Mask lower byte
		L	H	Write lower byte; Mask upper byte
		L	L	Write both bytes

Notes

- 14. H = Logic HIGH, L = Logic LOW, V = Valid Data, X = Don't Care, ↓ = toggle LOW, ↑ = toggle HIGH.
- 15. For write cycles, data-in is latched on the rising edge of \overline{CE} or \overline{WE} , whichever comes first.
- 16. \overline{WE} -controlled write cycle begins as a Read cycle and then A₁₆₋₂ is latched.
- 17. Addresses A₁₋₀ must remain stable for at least 10 ns during page mode operation.
- 18. Assumes \overline{CE} is LOW and \overline{ZZ} is HIGH for all cases. The \overline{UB} and \overline{LB} pins may be grounded if 1) the system does not perform byte writes and 2) the device is not configured as a 256 K x 8.

Ordering Information

Access time (ns)	Ordering Code	Package Diagram	Package Type	Operating Range
60	FM21L16-60-TG	51-85087	44-pin TSOP II	Industrial
	FM21L16-60-TGTR			

All the above parts are Pb-free.

Ordering Code Definitions

FM 21 L 16 - 60 -TG TR

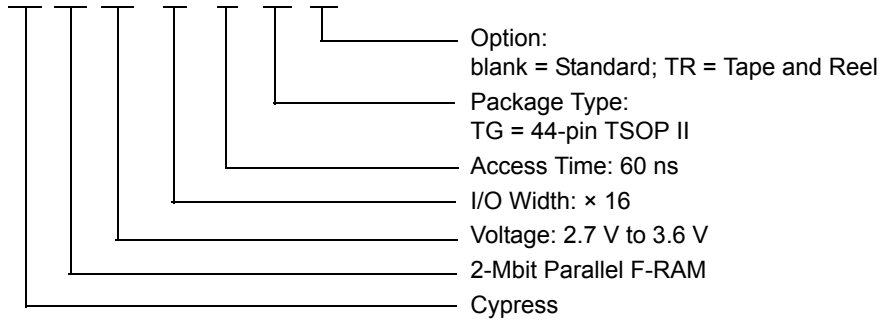

Not recommended for new designs.

Package Diagram

Figure 17. 44-pin TSOP Package Outline, 51-85087

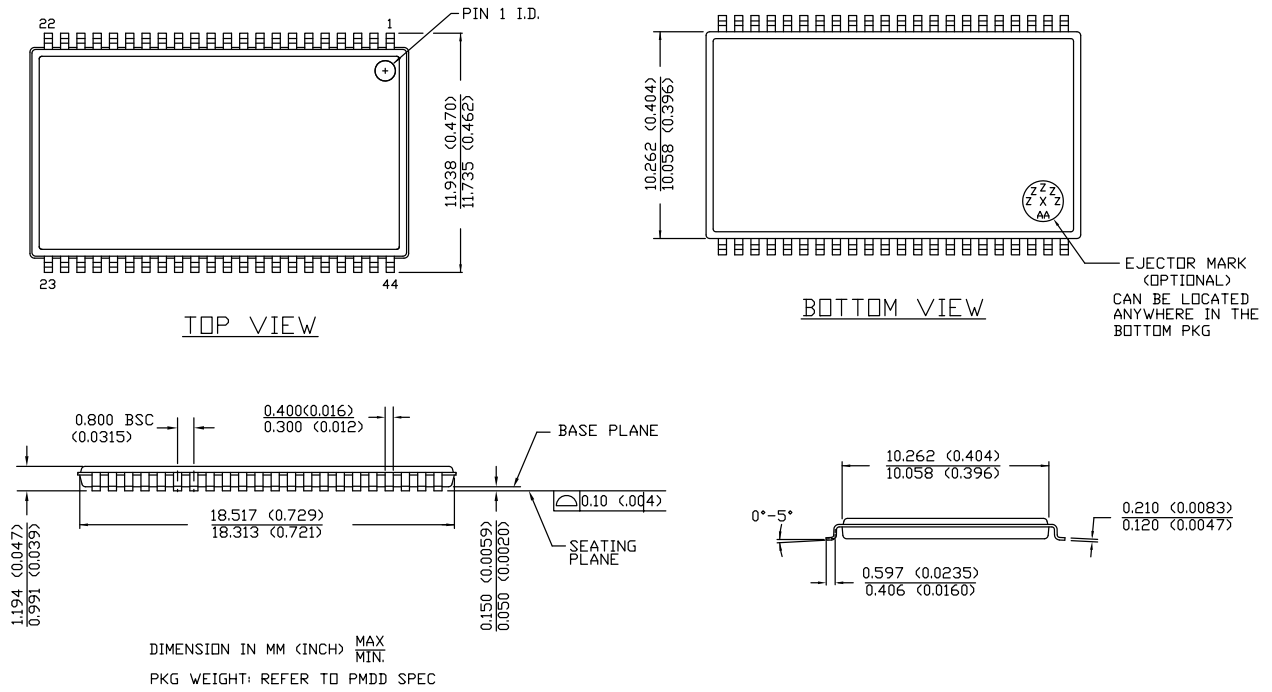

51-85087 *E

Not recommended for new designs.

Acronyms

Acronym	Description
CPU	Central Processing Unit
CMOS	Complementary Metal Oxide Semiconductor
EIA	Electronic Industries Alliance
F-RAM	Ferroelectric Random Access Memory
I/O	Input/Output
MCU	Microcontroller Unit
MPU	Microprocessor Unit
RoHS	Restriction of Hazardous Substances
R/W	Read and Write
SRAM	Static Random Access Memory
TSOP	Thin Small Outline Package

Document Conventions

Units of Measure

Symbol	Unit of Measure
°C	degree Celsius
Hz	hertz
kHz	kilohertz
kΩ	kilohm
MHz	megahertz
μA	microampere
μF	microfarad
μs	microsecond
mA	milliampere
ms	millisecond
MΩ	megaohm
ns	nanosecond
Ω	ohm
%	percent
pF	picofarad
V	volt
W	watt

Not recommended for new designs.

Document History Page

Document Title: FM21L16, 2-Mbit (128 K x 16) F-RAM Memory Document Number: 001-86191				
Rev.	ECN No.	Orig. of Change	Submission Date	Description of Change
**	3912933	GVCH	02/25/2013	New spec
*A	4191807	GVCH	11/14/2013	Added watermark as "Not recommended for new designs."
*B	4274811	GVCH	03/11/2014	Typo fixed: Changed datasheet status from "Preliminary to Final" Converted to Cypress standard format Updated Maximum Ratings table - Removed Moisture Sensitivity Level (MSL) - Added junction temperature and latch up current Updated Data Retention and Endurance table Added Thermal Resistance table Typo error fixed: Updated Address range from A ₁₇ -A ₀ to A ₁₆ -A ₀ for Figure 12 and Figure 13 Removed Package Marking Scheme (top mark)
*C	4574376	GVCH	11/19/2014	Added related documentation hyperlink in page 1.
*D	4879990	ZSK / PSR	08/11/2015	Updated Maximum Ratings : Removed "Maximum junction temperature". Added "Maximum accumulated storage time". Added "Ambient temperature with power applied". Updated to new template.

Not recommended for new designs.

Sales, Solutions, and Legal Information

Worldwide Sales and Design Support

Cypress maintains a worldwide network of offices, solution centers, manufacturer's representatives, and distributors. To find the office closest to you, visit us at [Cypress Locations](#).

Products

Automotive	cypress.com/go/automotive
Clocks & Buffers	cypress.com/go/clocks
Interface	cypress.com/go/interface
Lighting & Power Control	cypress.com/go/powerpsoc
Memory	cypress.com/go/memory
PSoC	cypress.com/go/psoc
Touch Sensing	cypress.com/go/touch
USB Controllers	cypress.com/go/USB
Wireless/RF	cypress.com/go/wireless

PSoC® Solutions

psoc.cypress.com/solutions
[PSoC 1](#) | [PSoC 3](#) | [PSoC 4](#) | [PSoC 5LP](#)

Cypress Developer Community

[Community](#) | [Forums](#) | [Blogs](#) | [Video](#) | [Training](#)

Technical Support

cypress.com/go/support

Not recommended for new designs.

© Cypress Semiconductor Corporation, 2013-2015. The information contained herein is subject to change without notice. Cypress Semiconductor Corporation assumes no responsibility for the use of any circuitry other than circuitry embodied in a Cypress product. Nor does it convey or imply any license under patent or other rights. Cypress products are not warranted nor intended to be used for medical, life support, life saving, critical control or safety applications, unless pursuant to an express written agreement with Cypress. Furthermore, Cypress does not authorize its products for use as critical components in life-support systems where a malfunction or failure may reasonably be expected to result in significant injury to the user. The inclusion of Cypress products in life-support systems application implies that the manufacturer assumes all risk of such use and in doing so indemnifies Cypress against all charges.

Any Source Code (software and/or firmware) is owned by Cypress Semiconductor Corporation (Cypress) and is protected by and subject to worldwide patent protection (United States and foreign), United States copyright laws and international treaty provisions. Cypress hereby grants to licensee a personal, non-exclusive, non-transferable license to copy, use, modify, create derivative works of, and compile the Cypress Source Code and derivative works for the sole purpose of creating custom software and or firmware in support of licensee product to be used only in conjunction with a Cypress integrated circuit as specified in the applicable agreement. Any reproduction, modification, translation, compilation, or representation of this Source Code except as specified above is prohibited without the express written permission of Cypress.

Disclaimer: CYPRESS MAKES NO WARRANTY OF ANY KIND, EXPRESS OR IMPLIED, WITH REGARD TO THIS MATERIAL, INCLUDING, BUT NOT LIMITED TO, THE IMPLIED WARRANTIES OF MERCHANTABILITY AND FITNESS FOR A PARTICULAR PURPOSE. Cypress reserves the right to make changes without further notice to the materials described herein. Cypress does not assume any liability arising out of the application or use of any product or circuit described herein. Cypress does not authorize its products for use as critical components in life-support systems where a malfunction or failure may reasonably be expected to result in significant injury to the user. The inclusion of Cypress' product in a life-support systems application implies that the manufacturer assumes all risk of such use and in doing so indemnifies Cypress against all charges.

Use may be limited by and subject to the applicable Cypress software license agreement.